

LINEAR INTEGRATED CIRCUITS

DESCRIPTION

The 5070 is a complete subcarrier regeneration system with automatic phase control applied to the oscillator. An amplifier chroma signal from the 5071 is applied to terminals No. 13 and No. 14, which are the automatic phase control (APC) and the automatic chroma control (ACC) inputs. APC and ACC detection is keyed by the horizontal pulse which also inhibits the oscillator output amplifier during the burst interval.

The ACC system uses a synchronous detector to develop a correction voltage at the differential output terminal Nos. 15 and 16. This control signal is applied to the input terminal Nos. 1 and 14 of the 5071. The APC system also uses a synchronous detector. The APC error voltage is internally coupled to the 3.58 MHz oscillator at balance; the phase of the signal at terminal No. 13 is in quadrature with the oscillator.

To accomplish phasing requirements, an RC phase shift network is used between the chroma input and terminal Nos. 13 and 14. The feedback loop of the oscillator is from terminal Nos. 7 and 8 back to No. 6. The same oscillator signal is available at terminal Nos. 7 and 8, but the dc output of the APC detector controls the relative signal levels at terminal Nos. 7 or 8. Because the output at terminal No. 8 is shifted in phase compared to the output at terminal No. 7, which is applied directly to the crystal circuit, control of the relative amplitudes at terminal Nos. 7 and 8 alters the phase in the feedback I_{cop} , thereby changing the frequency of the crystal oscillator. Balance adjustments of dc offsets are provided to establish an initial no-signal offset control in the ACC output, and a no-signal, on-frequency adjustment through the APC detector-amplifier circuit which controls the oscillator frequency. The oscillator output stage is differentially controlled at terminal Nos. 2 and 3 by the hue control input to terminal No. 1. The hue phase shift is accomplished by the external R, L, and C components that couple the oscillator output to the demodulator input terminals. The 5070 includes a shunt regulator to establish a 12Vdc supply.

FEATURES

- VOLTAGE CONTROLLED OSCILLATOR
- KEYED APC & ACC DETECTORS
- DC HUE CONTROL
- SHUNT REGULATOR

6-138

PIN CONFIGURATION

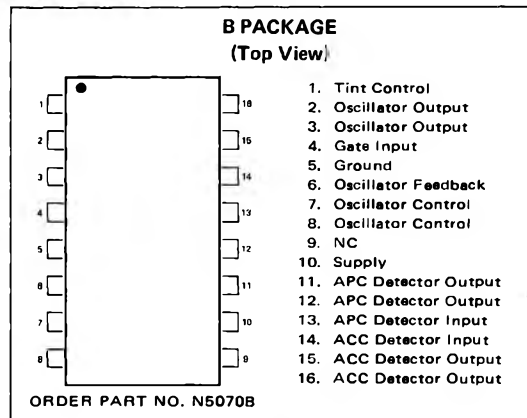

ABSOLUTE MAXIMUM RATINGS

(Values at $T_A = 25^\circ\text{C}$)

DC Supply Voltage and Current See Charts

Device Dissipation:

Up to $T_A = +70^\circ\text{C}$

Above $T_A = +70^\circ\text{C}$

530mW

Derate Linearly
at $6.7 \text{ mW}/^\circ\text{C}$

Ambient Temperature Range:

Operating

-40 to $+85^\circ\text{C}$

Storage

-65 to $+150^\circ\text{C}$

Lead Temperature (During Soldering):

At distance $1/32$ in. (3.17 mm) from
seating plane for 10s max

$+265^\circ\text{C}$

Voltage (Note 1)

TERM NO.	MIN. VOLTS	MAX. VOLTS
1	0	*
2	0	+16
3	0	+16
4	-5	Note 3
6	—	—
7	—	—
8	—	—
10	0	Note 4
11	0	Note 2
12	0	Note 2
13	0	Note 2
14	0	Note 2
15	0	+16
16	0	+16

Current

TERM NO.	I_j mA	I_O mA
1	20	1
2	—	—
3	—	—
4	—	1
10	Note 4	1
11	—	—
12	—	—
13	20	1
14	20	1

NOTES:

1. With respect to terminal No. 5 and with terminal No. 10 connected through 470Ω to +24V.
2. Regulated voltage at terminal No. 10.
3. Controlled by max. input current.
4. Limited by dissipation.

SCHEMATIC DIAGRAM

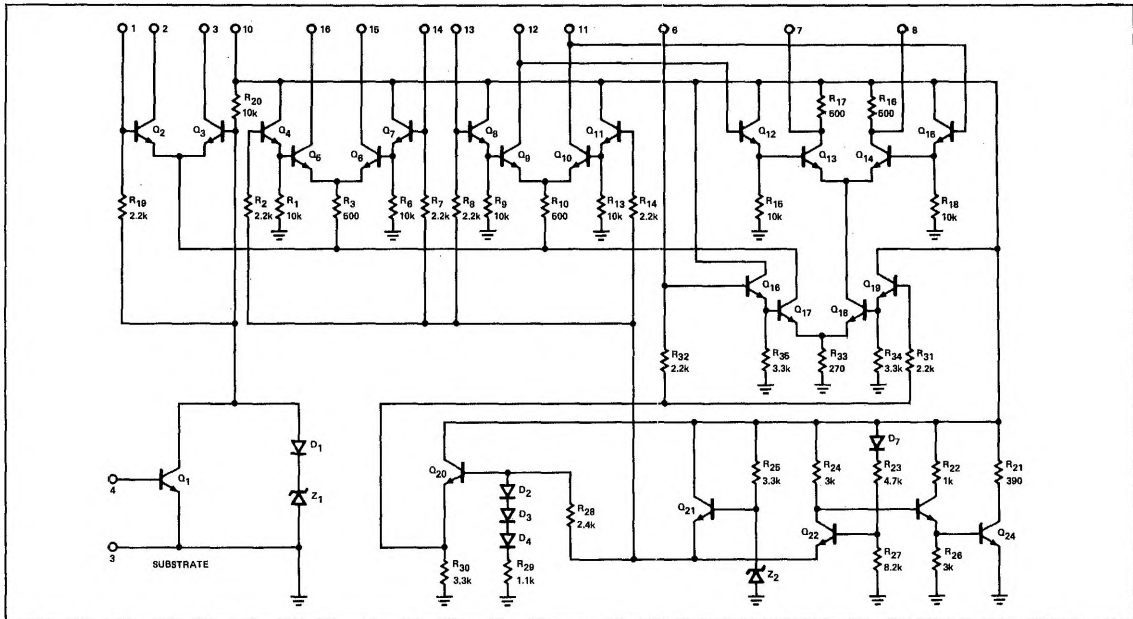

FUNCTIONAL DIAGRAM

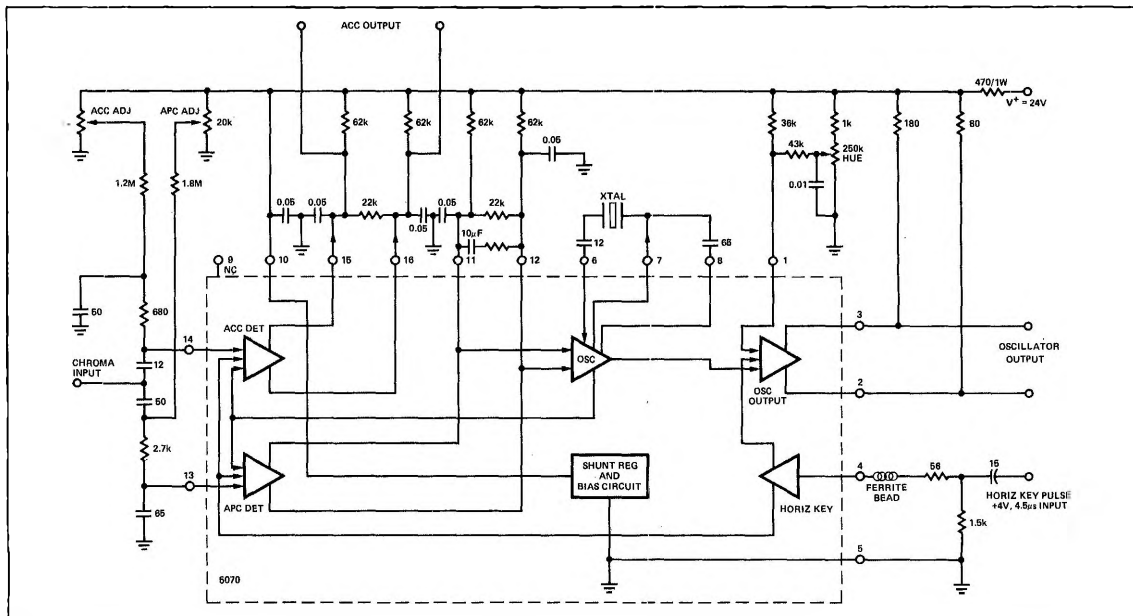

NOTES:

1. All resistance values are in ohms
2. Unless otherwise indicated all capacitance values less than 10 are in microfarads - 10 or greater are in picofarads.