

Audio decibel level detector with meter driver

AN1991

Author: Robert J. Zavrel Jr.

DESCRIPTION

Although the NE604 was designed as an RF device intended for the cellular radio market, it has features which permit other design configurations. One of these features is the Received Signal Strength Indicator (RSSI). In a cellular radio, this function is necessary for continuous monitoring of the received signal strength by the radio's microcomputer. This circuit provides a logarithmic response proportional to the input signal level. The NE604 can provide this logarithmic response over an 80dB range up to a 15MHz operating frequency. This paper describes a technique which optimizes this useful function within the audio band.

A sensitive audio level indicator circuit can be constructed using two integrated circuits: the NE604 and NE532. This circuit draws very little power (less than 5mA with a single 6V power supply) making it ideal for portable battery operated equipment. The small size and low-power consumption belie the 80dB dynamic range and 10.5 μ V sensitivity.

The RSSI function requires a DC output voltage which is proportional to the \log_{10} of the input signal level. Thus a standard 0-5 voltmeter can be linearly calibrated in decibels over a single 80dB range. The entire circuit is composed of 9 capacitors and two resistors along with the two ICs. No tuning or calibration is required in a manufacturing setting.

The Audio Input vs Output Graph shows that the circuit is within 1.5dB tolerance over the 80dB range for audio frequencies from 100Hz to 10kHz. Higher audio levels can be measured by placing an attenuator ahead of the input capacitor. The input impedance is high (about 50k), so lower impedance terminations (50 or 600 Ω) will not be affected by the input impedance. If very accurate tracking is required (<0.5dB accuracy), a 40 or 50dB segment can be "selected". A range switch can then be added with appropriate attenuators if more than 40 or 50dB dynamic range is required.

There are two amplifier sections in the 604 with 2 and 3 stages in the first and second sections respectively. Each stage outputs a sample current to a summing circuit. The summing circuit has a current mirror which appears at Pin 5. This current is proportional to the \log_{10} of the input audio signal. A voltage is dropped across the 100k resistor by the current, and a 0.1 μ F capacitor is used to bypass and filter the output signal. The 532 op amp is used as a buffer and meter driver, although a digital voltmeter could replace both the op amp and the meter shown. The rest of the capacitors are used for power supply and amplifier input bypassing.

The RC circuit between Pins 14 and 12 forms a low-pass filter which can be adjusted by changing the value of C1. Raising the capacitance will lower the cut-off frequency and also lower the zero signal output resting voltage (about 0.6V). Lowering the capacitance value will have the opposite effect with some reduction in dynamic range, but will raise the frequency response. The 2k Ω resistor value provides the near-ideal inter-stage loss for maximum RSSI linearity. C2 can also be changed. The trade-off here is between output damping and ripple. Most analog and digital metering methods will tend to cancel the effects of small or moderate ripple voltages through integration, but high ripple voltages should be avoided.

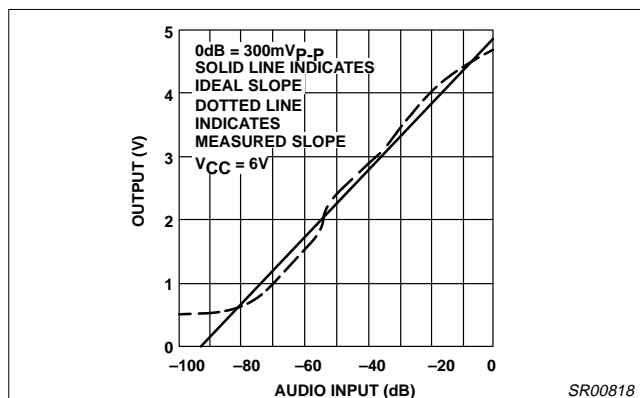

Figure 1.

A second op amp is used with an optional second filter. This filter has the advantage of a low impedance signal source by virtue of the first op amp. Again, a trade-off exists between meter damping and ripple attenuation. If very low ripple and low damping are both required, a more complex active low-pass filter should be constructed.

Some applications of this circuit might include:

1. Portable acoustic analyzer
2. Microphone tester
3. Audio spectrum analyzer
4. VU meters
5. S-meter for direct conversion radio receiver
6. Audio dynamic range testers
7. Audio analyzers (THD, noise, separation, response, etc.)

Audio decibel level detector with meter driver

AN1991

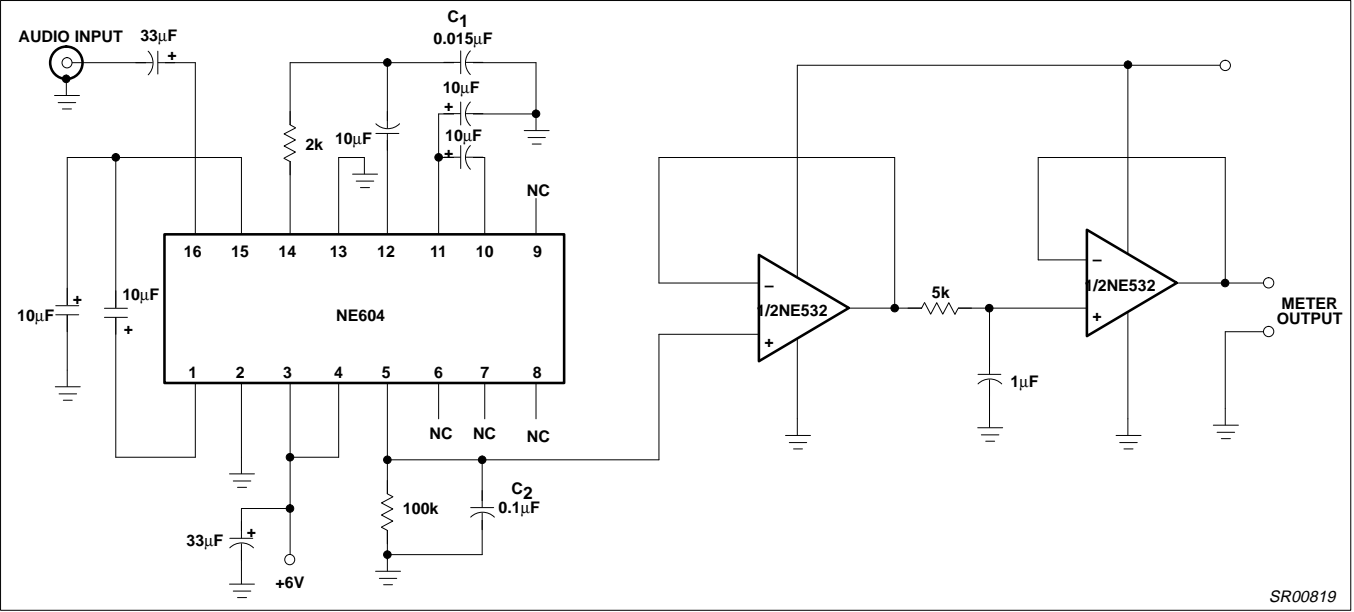

SR00819

Figure 2.