

**OBSOLETE PRODUCT
NO RECOMMENDED REPLACEMENT**
Call Central Applications 1-888-468-3774
or email: centapp@intersil.com

220MHz, Video Line Driver, High Speed Operational Amplifier

The CA3450 is a large signal video line driver and high speed operational amplifier capable of driving 50Ω transmission lines and flash A/Ds. The uncompensated unity gain crossing occurs at 230MHz without load. It can operate at dual or single supplies of ±7.25V or 14.5V, respectively. The CA3450 can be compensated with a single capacitor network. It has output drive capability of 75mA SINK or SOURCE. The CA3450 is capable of driving Flash A/Ds in video or high speed instrumentation (accurate) applications with bandwidth up to 10MHz. Offset voltage nulling terminals are also available.

Pinout

**CA3450
(PDIP)
TOP VIEW**

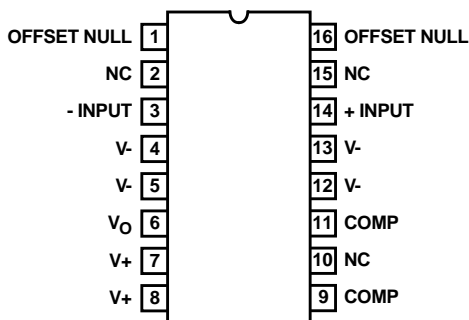

Features

- High Open Loop Gain at Video Frequencies
- $A_{OL} \dots \dots \dots >40dB$ at $f = 5MHz$
- Power Bandwidth of 10MHz $A_{CL} = 5; V_O = \pm 3.5V$
- Slew Rate at Full Load $330V/\mu s$ ($A_V \geq 10$)
- $f_T = 220MHz$; $C_C = 0pF$ With a Load of $50\Omega || 20pF || 1M\Omega$ (Scope Input)
- $V_{OUT} = \pm 4.1V$ Into 75Ω
- Offset Null Terminals

Applications

- Video Line Driver
- High Frequency Unity Gain Buffer
- Pulse Amplifier
- High Speed Comparator
- High Frequency Oscillator and Video Amplifiers
- Driver for A/Ds in Video Applications 10MHz BW

Part Number Information

PART NUMBER	TEMP. RANGE (°C)	PACKAGE	PKG. NO.
CA3450E	-40 to 85	16 Ld PDIP	E16.3

Block Diagram

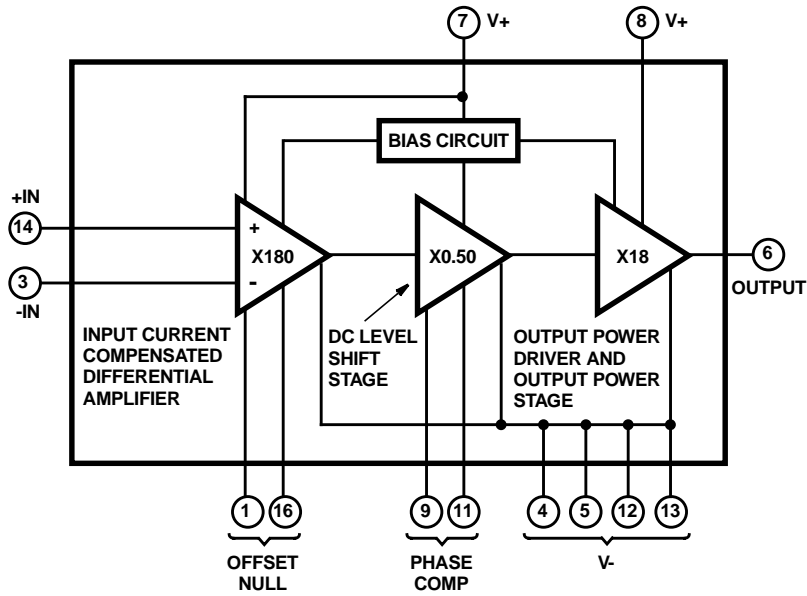

Schematic Diagram

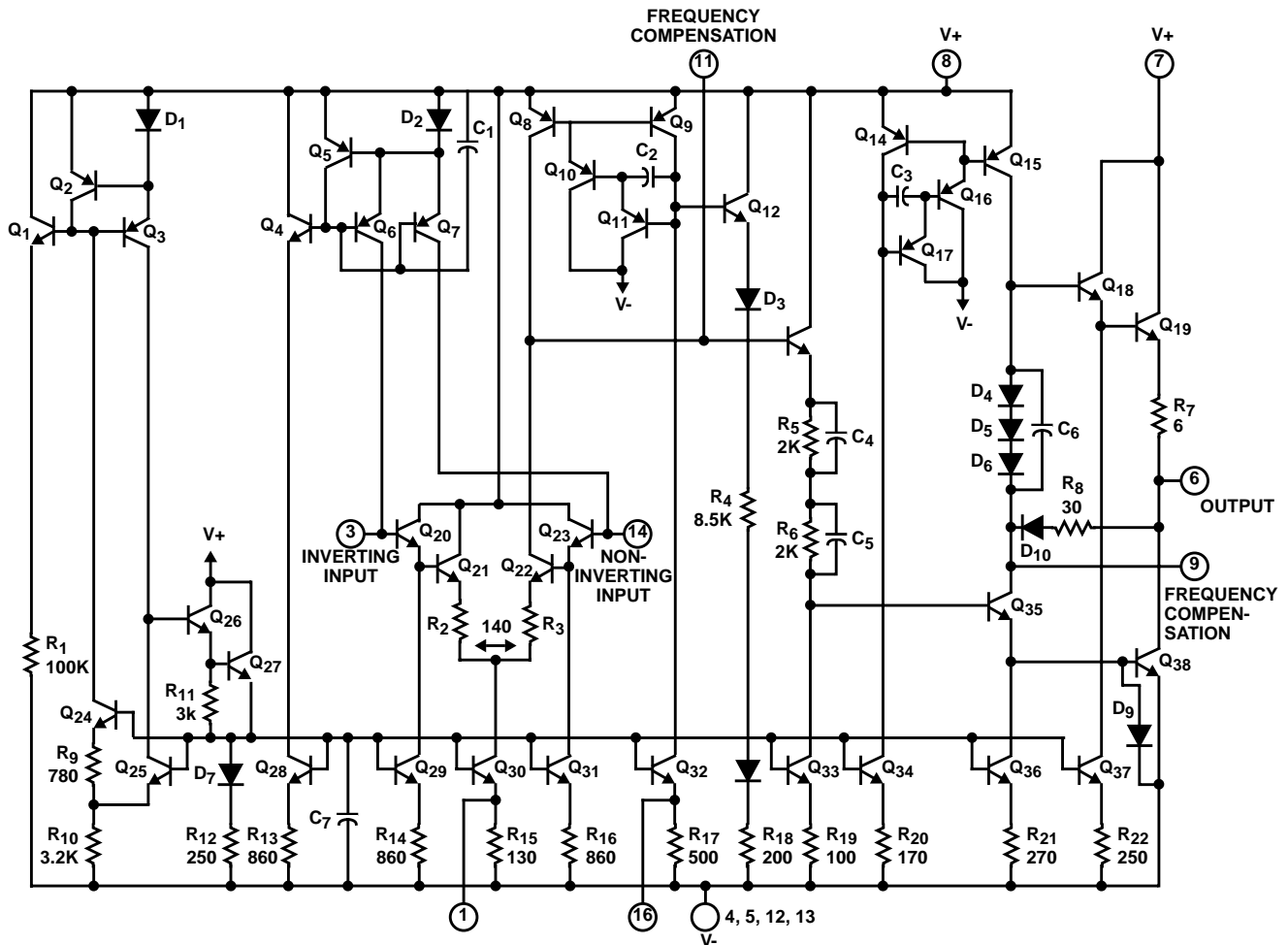

Absolute Maximum Ratings

Supply Voltage (Between V+ and V- Terminals) 14.5V
 Differential Input Voltage5V
 Output Current 100mA

Operating Conditions

Temperature Range -40°C to 85°C

CAUTION: Stresses above those listed in "Absolute Maximum Ratings" may cause permanent damage to the device. This is a stress only rating and operation of the device at these or any other conditions above those indicated in the operational sections of this specification is not implied.

NOTE:

1. θ_{JA} is measured with the component mounted on an evaluation PC board in free air.

Thermal Information

Thermal Resistance (Typical, Note 1) θ_{JA} (°C/W)
 PDIP Package 60
 Maximum Junction Temperature (Plastic Package) 150°C
 Maximum Storage Temperature Range -65°C to 150°C
 Maximum Lead Temperature (Soldering 10s) 300°C

Electrical Specifications $C_C = 5\text{pF}$, $V_{\text{SUPPLY}} = \pm 6\text{V}$, Unless Otherwise Specified

PARAMETER	SYMBOL	TEST CONDITIONS	TEMP. (°C)	MIN	TYP	MAX	UNITS	
DC								
Input Offset Voltage	$ V_{IO} $		25	-	8	20	mV	
			Full	-	10	35	mV	
Input Bias current	$ I_{IB} $		25	-	100	400	nA	
Input Offset Current	$ I_{IO} $		25	-	50	200	nA	
Open Loop DC Gain	A_{OL}	$V_{OUT} = \pm 2.5\text{V}$, $R_L = 50\Omega$	25	60	70	-	dB	
			Full	55	-	-	dB	
Power Supply Rejection Ratio	PSRR	$\Delta V = \pm 1\text{V}$	25	55	65	-	dB	
Common Mode Rejection Ratio	CMRR	$V_{ICR} = \pm 3.5\text{V}$	25	50	60	-	dB	
Common Mode Input Range	V_{ICR}		25	± 3.5	± 3.7	-	V	
			Full	± 3.0	-	-	V	
Supply Current	I_+		25	-	30	40	mA	
			Full	-	-	50	mA	
DYNAMIC								
-3dB Bandwidth $A_V = 1$ (See Figure 2) $C_C = 5\text{pF}$		No Load	25	-	200	-	MHz	
		$R_L = 1\text{M}\Omega 20\text{pF}$	25	-	190	-	MHz	
		$R_L = 50\Omega 20\text{pF}$	25	-	185	-	MHz	
Bandwidth (Unity Gain Crossing) $A_V = \text{Open Loop}$ $C_C = 0$ (See Figure 1)		No Load	25	210	230	-	MHz	
		$R_L = 20\text{pF} 1\text{M}\Omega$	25	180	200	-	MHz	
		$R_L = 50\Omega 20\text{pF}$	25	180	220	-	MHz	
Bandwidth (Unity Gain Crossing) $A_V = 10$, $C_C = 0\text{pF}$ $R_{\text{FEEDBACK}} = 450\Omega$ $R_{\text{PIN } 3-G} = 50\Omega$ (See Figure 2)		No Load	25	200	210	-	MHz	
		50Ω	25	175	190	-	MHz	
		$1\text{M} 20\text{pF}$	25	180	195	-	MHz	
		$50\Omega 1\text{M} 20\text{pF}$	25	170	188	-	MHz	
Transient Response, Overshoot (See Figure 3)	OS	$A_V = 1$, $C_C = 5\text{pF}$	$R_L = 50\Omega 20\text{pF}$	25	-	30	-	%
			No Load	25	-	20	-	%
		$A_V \geq 10$, $C_C = 0\text{pF}$, $R_L = 50\Omega 20\text{pF}$	25	-	10	-	%	
Settling Time (See Figure 5) (2V Step, $R_L = 50\Omega 20\text{pF}$)	t_S	$A_V = -1$, $C_C = 5\text{pF}$, 0.1%, 10 Bits	25	-	35	-	ns	
		$A_V = 1$, $C_C = 5\text{pF}$, 0.1%, 10 Bits	25	-	50	-	ns	
		$A_V = 10$, $C_C = 0\text{pF}$, 0.1%, 10 Bits	25	-	35	-	ns	
		$A_V = 10$, $C_C = 0\text{pF}$, 1.0%, 7 Bits	25	-	25	-	ns	

CA3450

Electrical Specifications $C_C = 5\text{pF}$, $V_{\text{SUPPLY}} = \pm 6\text{V}$, Unless Otherwise Specified (Continued)

PARAMETER	SYMBOL	TEST CONDITIONS	TEMP. (°C)	MIN	TYP	MAX	UNITS	
Slew Rate (See Figures 2, 4)	SR	$A_V = 1$, $C_C = 5\text{pF}$	No Load	25	-	220	-	V/ μs
			$R_L = 50\Omega 20\text{pF}$	25	-	160	-	V/ μs
		$A_V \geq 10$, $C_C = 0\text{pF}$	No Load	25	370	440	-	V/ μs
			$R_L = 50\Omega 20\text{pF}$	25	300	330	-	V/ μs
Full Power Bandwidth (FPBW = $\text{SR}/\pi V_{\text{P-P}}$)	FPBW	$A_V = 5$, $C_C = 5\text{pF}$ $V_{\text{OUT}} = \pm 3.5\text{V}$	No Load	25	-	10	-	MHz
			$R_L = 50\Omega 20\text{pF}$	25	-	7.2	-	MHz
		$A_V \geq 10$, $C_C = 0\text{pF}$ $V_{\text{OUT}} = \pm 2.0\text{V}$	No Load	25	29	35	-	MHz
			$R_L = 50\Omega 20\text{pF}$	25	24	26	-	MHz
Input Noise Voltage	e_N	$f = 1\text{kHz}$	25	-	12	-	nV/ $\sqrt{\text{Hz}}$	
Differential Gain	DG	See Figure 8	25	-	0.2	-	%	
Differential Phase	DP	See Figure 8	25	-	0.2	-	Degrees	
Output Current	I_{OUT}	Into +4V or -4V	25	60	75	-	mA	
Output Voltage Swing	$V_{\text{OM}+}$	$R_L = 75\Omega$	25	3.9	4.1	-	V	
	$V_{\text{OM}-}$		25	-3.9	-4.1	-	V	
Input Capacitance	C_I	$f = 1\text{MHz}$	25	-	2.2	-	pF	
Input Resistance	R_I		25	-	1	-	M Ω	
Output Resistance	R_{OUT}	See Figure 14, $A_V = 1$, 30MHz	25	-	4	-	Ω	

Test Circuits and Waveforms

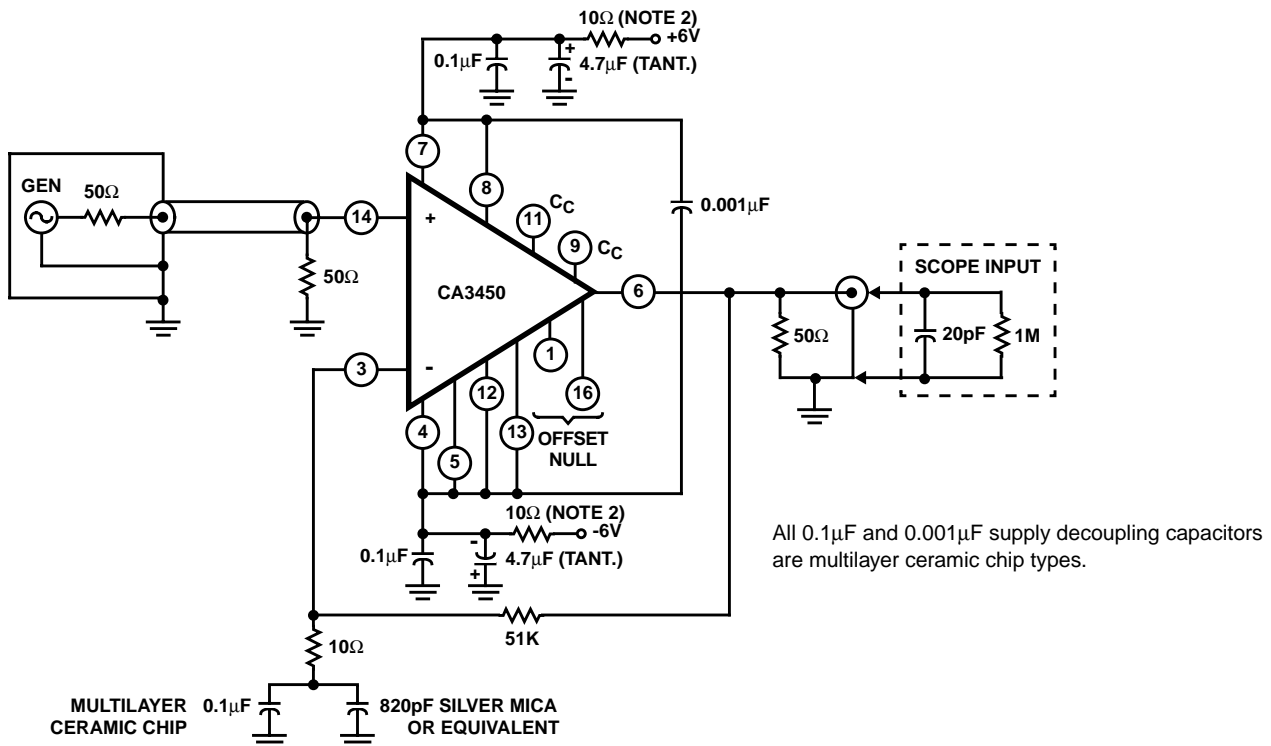

NOTE:

- A 10 Ω , 1/4W supply decoupling resistor is shown in all application circuits of this device. The resistor serves two purposes. First it provides a means of decoupling the IC directly at its terminal without introducing additional supply resonance due to parallel connected capacitors. Second, it also provides protection for the device in event of a sustained short circuit applied directly to the output terminals.

FIGURE 1. OPEN LOOP GAIN vs FREQUENCY TEST CIRCUIT

Test Circuits and Waveforms (Continued)

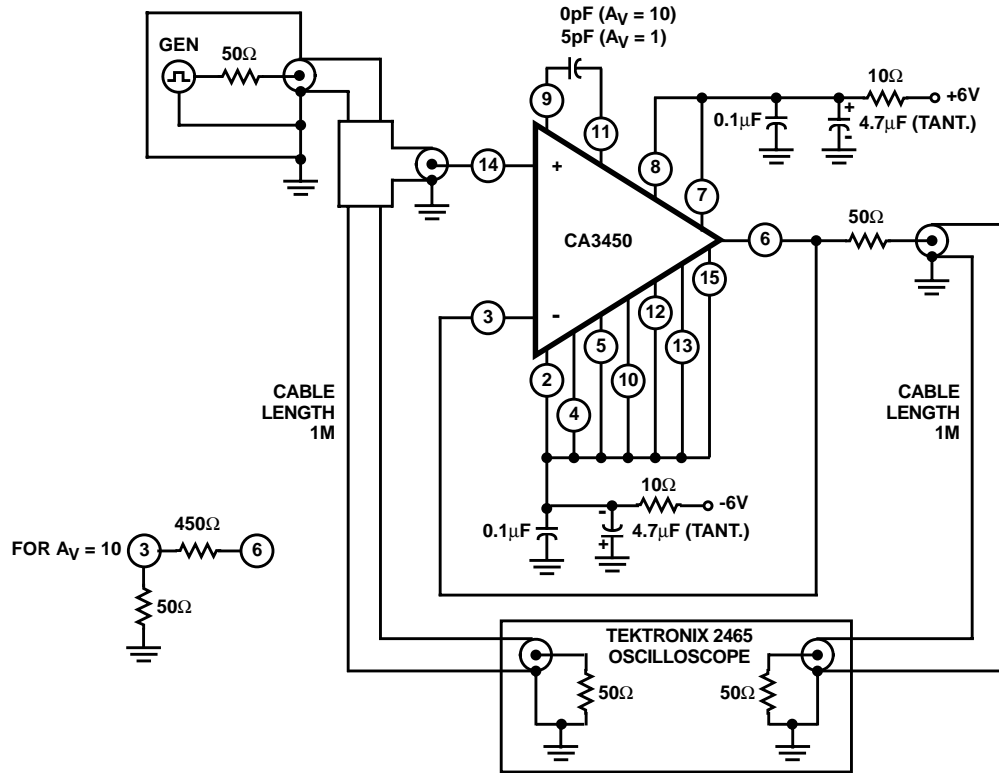

FIGURE 2. UNITY GAIN AND X10 NON-INVERTING AMPLIFIER/AND SLEW RATE TEST CIRCUIT

Transient Response Waveforms

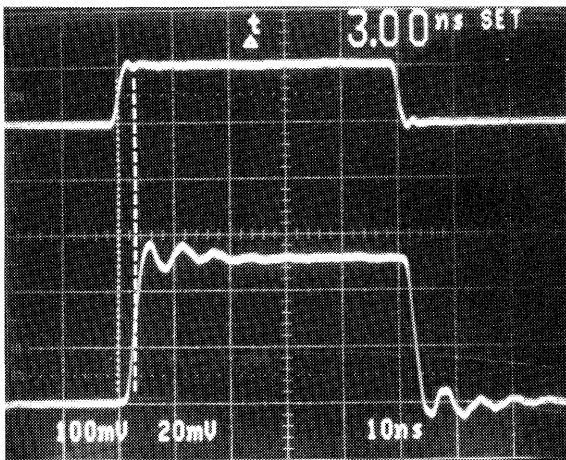

FIGURE 3. TRANSIENT RESPONSE WAVEFORM

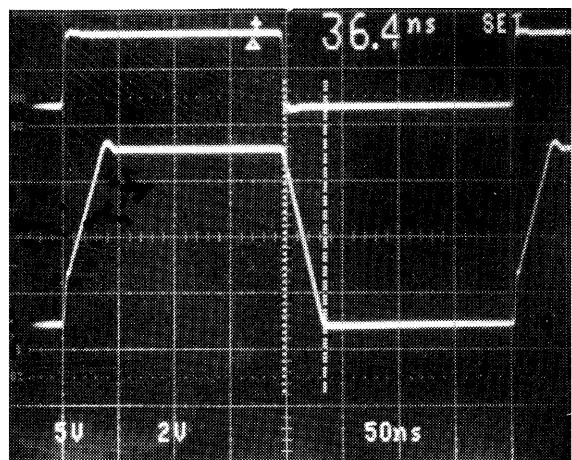

FIGURE 4. SLEW RATE WAVEFORM

Test Circuits and Waveforms (Continued)

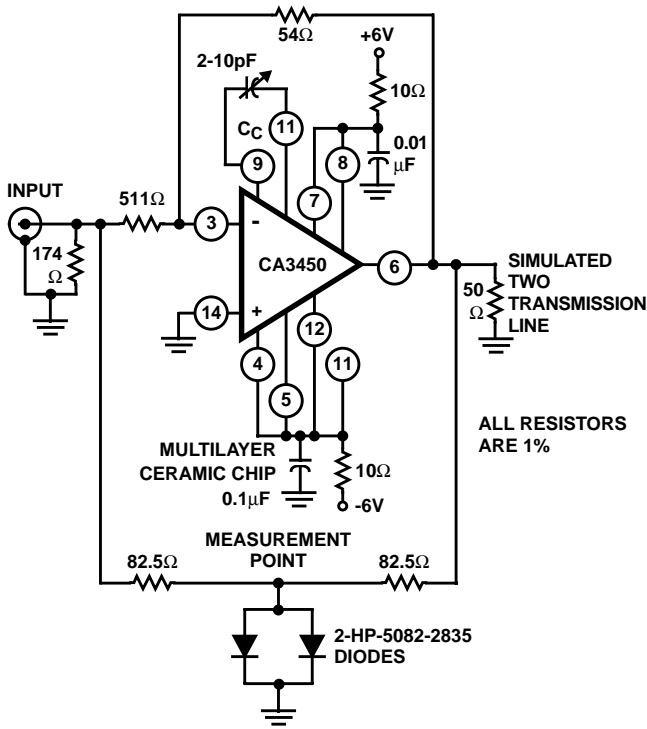

FIGURE 5. CIRCUIT USED TO MEASURE SETTLING TIME

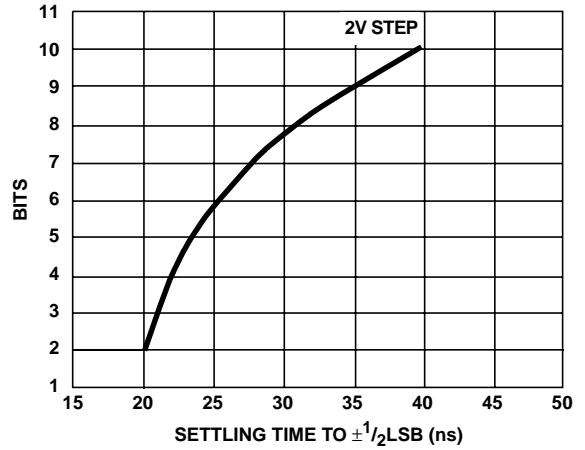

FIGURE 6. ACCURACY IN BITS AS A FUNCTION OF SETTLING TIME

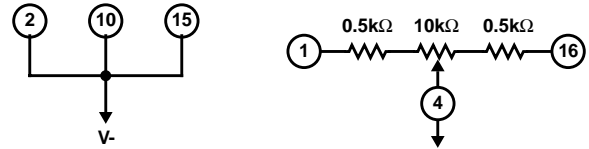

FIGURE 7. NULLING CIRCUIT FOR THE CA3450

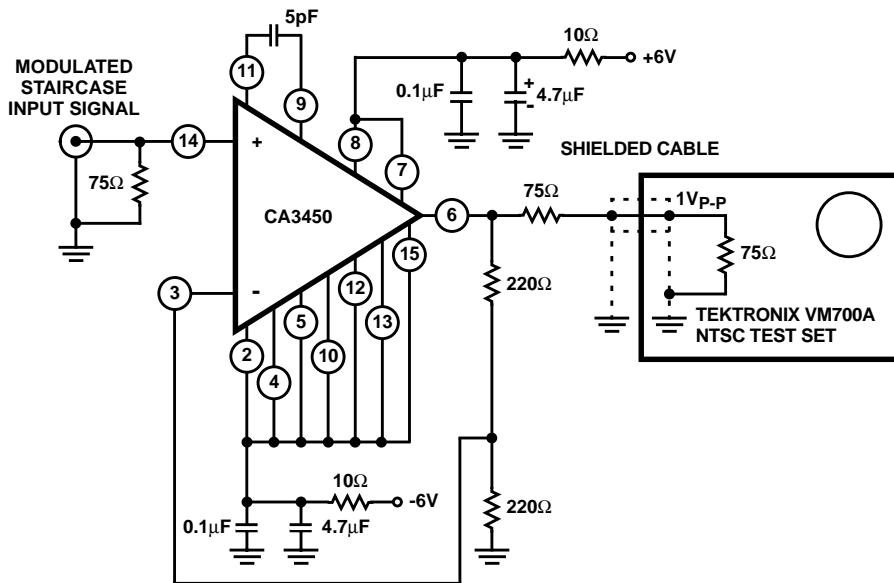

FIGURE 8. CONFIGURATION USED TO MEASURE DIFFERENTIAL GAIN AND PHASE

Test Circuits and Waveforms (Continued)

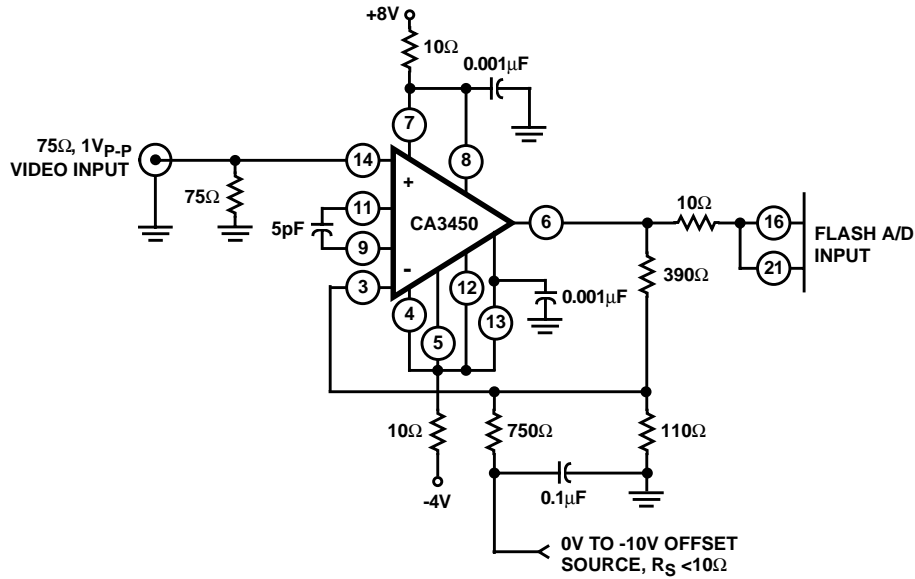

FIGURE 9. TYPICAL HIGH BANDWIDTH X5 AMPLIFIER FOR DRIVING THE CA3318 FLASH A/D

Typical Performance Curves

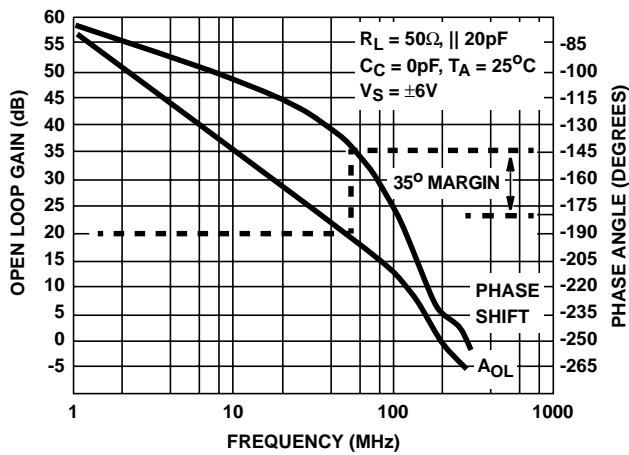

FIGURE 10. BODE PLOT FOR THE CA3450

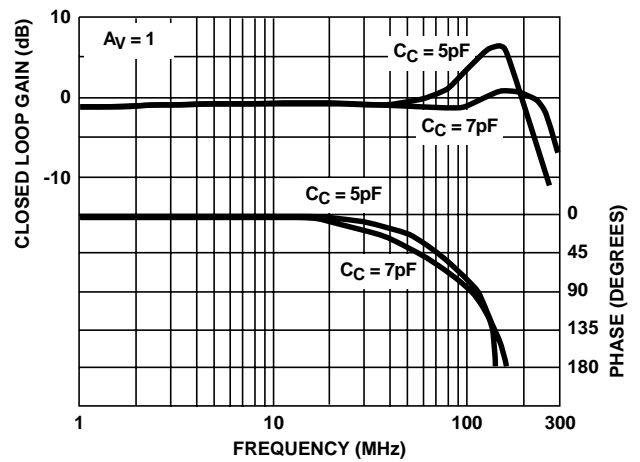

FIGURE 11. CLOSED LOOP GAIN AND PHASE vs FREQUENCY

Typical Performance Curves (Continued)

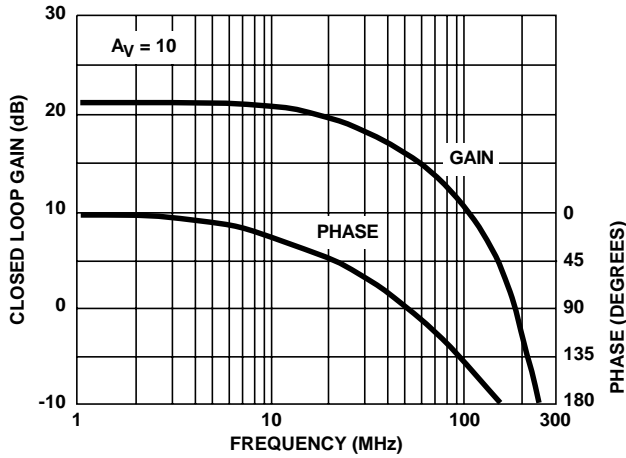

FIGURE 12. CLOSED LOOP GAIN AND PHASE vs FREQUENCY

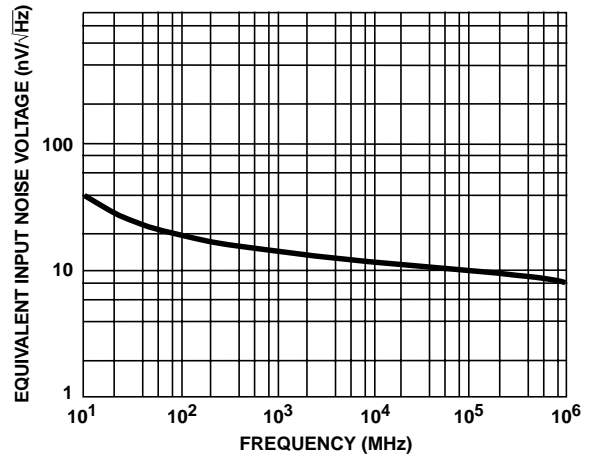

FIGURE 13. EQUIVALENT INPUT NOISE vs FREQUENCY

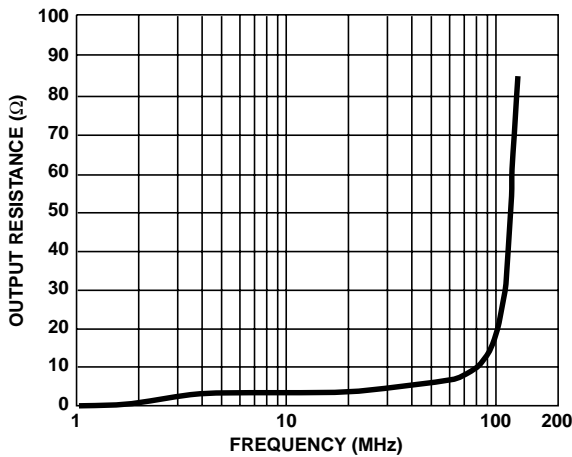

FIGURE 14. OUTPUT RESISTANCE vs FREQUENCY

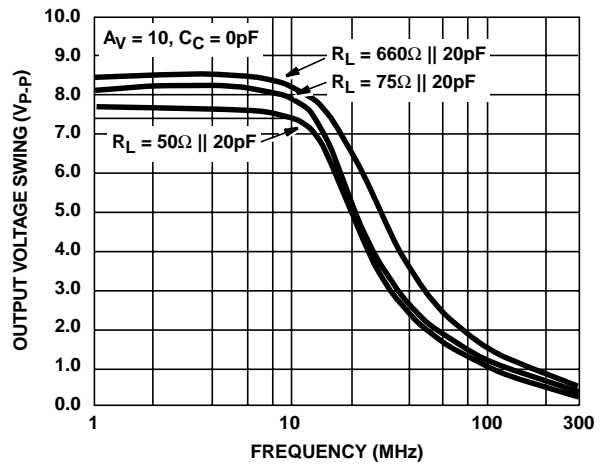
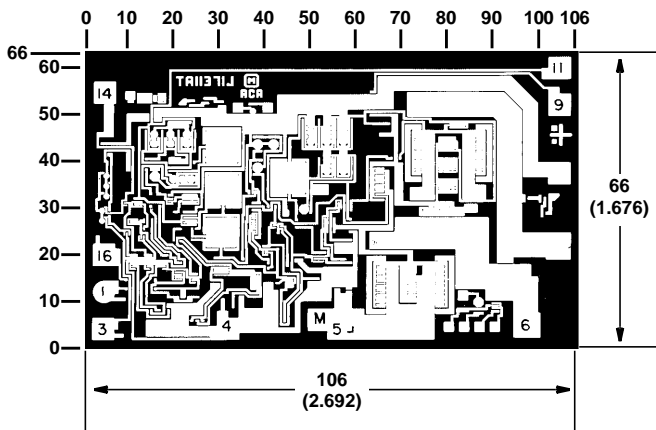

FIGURE 15. OUTPUT VOLTAGE vs FREQUENCY

Metallization Mask Layout



Dimensions in parenthesis are in millimeters and are derived from the basic inch dimensions as indicated. Grid graduations are in mils (10^{-3} inch).

The photographs and dimensions of each CMOS chip represent a chip when it is part of the wafer. When the wafer is cut into chips, the angle of cleavage may vary with respect to the chip face for different chips. The actual dimensions of the isolated chip, therefore, may differ slightly from the nominal dimensions shown. The user should consider a tolerance of -3mils to +6mils applicable to the nominal dimensions shown.