

128K x 8 Static RAM

Features

- Pin- and function-compatible with CY7C1018BV33
- High speed
 - $t_{AA} = 8, 10, 12, 15$ ns
- CMOS for optimum speed/power
- Center power/ground pinout
- Data retention at 2.0V
- Automatic power-down when deselected
- Easy memory expansion with \overline{CE} and \overline{OE} options
- Available in 300-mil-wide 32-pin SOJ

Functional Description^[1]

The CY7C1018CV33 is a high-performance CMOS static RAM organized as 131,072 words by 8 bits. Easy memory expansion is provided by an active LOW Chip Enable (\overline{CE}), an active LOW Output Enable (\overline{OE}), and three-state drivers. This

device has an automatic power-down feature that significantly reduces power consumption when deselected.

Writing to the device is accomplished by taking Chip Enable (\overline{CE}) and Write Enable (\overline{WE}) inputs LOW. Data on the eight I/O pins (I/O_0 through I/O_7) is then written into the location specified on the address pins (A_0 through A_{16}).

Reading from the device is accomplished by taking Chip Enable (\overline{CE}) and Output Enable (\overline{OE}) LOW while forcing Write Enable (\overline{WE}) HIGH. Under these conditions, the contents of the memory location specified by the address pins will appear on the I/O pins.

The eight input/output pins (I/O_0 through I/O_7) are placed in a high-impedance state when the device is deselected (\overline{CE} HIGH), the outputs are disabled (\overline{OE} HIGH), or during a write operation (\overline{CE} LOW, and \overline{WE} LOW).

The CY7C1018CV33 is available in a standard 300-mil-wide SOJ.

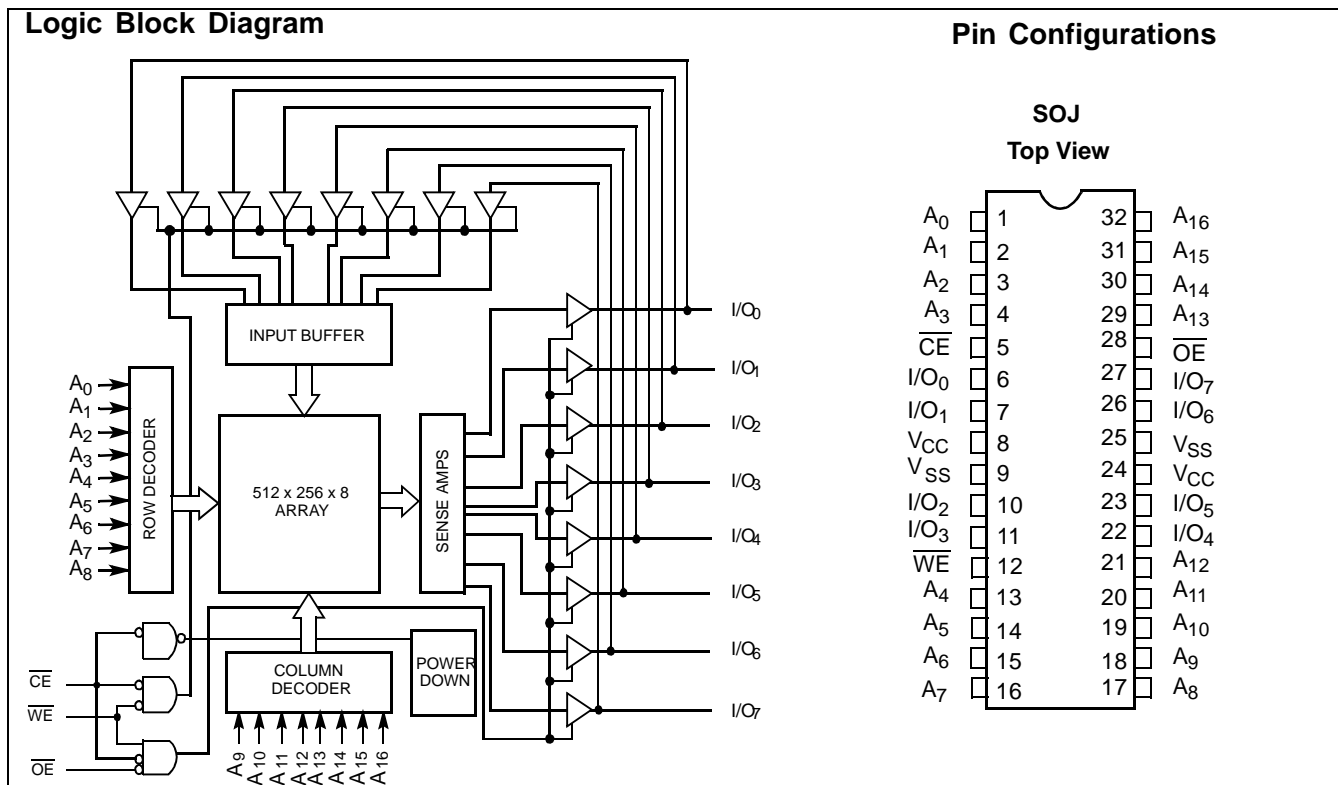

Selection Guide

| | 7C1018CV33-8 | 7C1018CV33-10 | 7C1018CV33-12 | 7C1018CV33-15 | Unit |
|---------------------------|--------------|---------------|---------------|---------------|------|
| Maximum Access Time | 8 | 10 | 12 | 15 | ns |
| Maximum Operating Current | 95 | 90 | 85 | 80 | mA |
| Maximum Standby Current | 5 | 5 | 5 | 5 | mA |

Note:

1. For guidelines on SRAM system designs, please refer to the 'System Design Guidelines' Cypress application note, available on the internet at www.cypress.com.

Maximum Ratings

(Above which the useful life may be impaired. For user guidelines, not tested.)

Storage Temperature -65°C to +150°C
 Ambient Temperature with Power Applied..... -55°C to +125°C
 Supply Voltage on V_{CC} to Relative GND^[2] ... -0.5V to + 4.6V
 DC Voltage Applied to Outputs^[7] in High-Z State -0.5V to V_{CC} + 0.5V

DC Input Voltage^[2] -0.5V to V_{CC} + 0.5V
 Current into Outputs (LOW)..... 20 mA
 Static Discharge Voltage..... > 2001V (per MIL-STD-883, Method 3015)
 Latch-up Current..... > 200 mA

Operating Range

| Range | Ambient Temperature | V _{CC} |
|------------|---------------------|-----------------|
| Commercial | 0°C to +70°C | 3.3V ± 10% |

Electrical Characteristics Over the Operating Range

| Parameter | Description | Test Conditions | 7C1018CV33 -8 | | 7C1018CV33 -10 | | 7C1018CV33 -12 | | 7C1018CV33 -15 | | Unit |
|--------------------------------|--|---|---------------|-----------------------|----------------|-----------------------|----------------|-----------------------|----------------|-----------------------|------|
| | | | Min. | Max. | Min. | Max. | Min. | Max. | Min. | Max. | |
| V _{OH} | Output HIGH Voltage | V _{CC} = Min., I _{OH} = -4.0 mA | 2.4 | | 2.4 | | 2.4 | | 2.4 | | V |
| V _{OL} | Output LOW Voltage | V _{CC} = Min., I _{OL} = 8.0 mA | | 0.4 | | 0.4 | | 0.4 | | 0.4 | V |
| V _{IH} | Input HIGH Voltage | | 2.0 | V _{CC} + 0.3 | 2.0 | V _{CC} + 0.3 | 2.0 | V _{CC} + 0.3 | 2.0 | V _{CC} + 0.3 | V |
| V _{IL} | Input LOW Voltage ^[2] | | -0.3 | 0.8 | -0.3 | 0.8 | -0.3 | 0.8 | -0.3 | 0.8 | V |
| I _{IX} | Input Load Current | GND ≤ V _I ≤ V _{CC} | -1 | +1 | -1 | +1 | -1 | +1 | -1 | +1 | μA |
| I _{OZ} | Output Leakage Current | GND ≤ V _I ≤ V _{CC} , Output Disabled | -1 | +1 | -1 | +1 | -1 | +1 | -1 | +1 | μA |
| I _{OS} ^[3] | Output Short Circuit Current | V _{CC} = Max., V _{OUT} = GND | | -300 | | -300 | | -300 | | -300 | mA |
| I _{CC} | V _{CC} Operating Supply Current | V _{CC} = Max., I _{OUT} = 0 mA, f = f _{MAX} = 1/t _{RC} | | 95 | | 90 | | 85 | | 80 | mA |
| I _{SB1} | Automatic CE Power-down Current —TTL Inputs | Max. V _{CC} , CE ≥ V _{IH} , V _{IN} ≥ V _{IH} or V _{IN} ≤ V _{IL} , f = f _{MAX} | | 15 | | 15 | | 15 | | 15 | mA |
| I _{SB2} | Automatic CE Power-down Current —CMOS Inputs | Max. V _{CC} , CE ≥ V _{CC} - 0.3V, V _{IN} ≥ V _{CC} - 0.3V, or V _{IN} ≤ 0.3V, f = 0 | | 5 | | 5 | | 5 | | 5 | mA |

Capacitance^[4]

| Parameter | Description | Test Conditions | Max. | Unit |
|------------------|--------------------|--|------|------|
| C _{IN} | Input Capacitance | T _A = 25°C, f = 1 MHz, V _{CC} = 3.3V | 8 | pF |
| C _{OUT} | Output Capacitance | | 8 | pF |

Notes:

- V_{IL} (min.) = -2.0V for pulse durations of less than 20 ns.
- Not more than one output should be shorted at one time. Duration of the short circuit should not exceed 30 seconds.
- Tested initially and after any design or process changes that may affect these parameters.

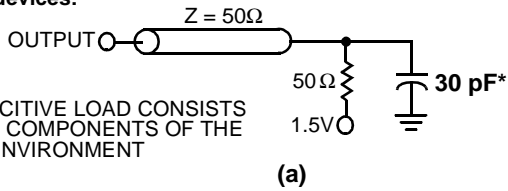
AC Test Loads and Waveforms^[5]
8-ns devices:

* CAPACITIVE LOAD CONSISTS OF ALL COMPONENTS OF THE TEST ENVIRONMENT

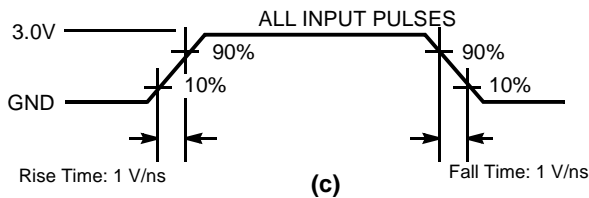
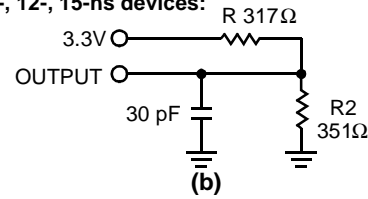
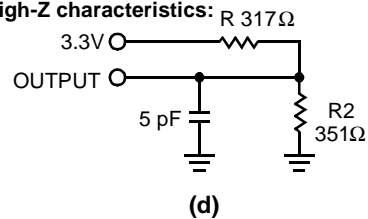
10-, 12-, 15-ns devices:

High-Z characteristics:

Switching Characteristics Over the Operating Range^[6]

| Parameter | Description | 7C1018CV33-8 | | 7C1018CV33-10 | | 7C1018CV33-12 | | 7C1018CV33-15 | | Unit |
|---------------------------------------|-------------------------------------|--------------|------|---------------|------|---------------|------|---------------|------|------|
| | | Min. | Max. | Min. | Max. | Min. | Max. | Min. | Max. | |
| Read Cycle | | | | | | | | | | |
| t_{RC} | Read Cycle Time | 8 | | 10 | | 12 | | 15 | | ns |
| t_{AA} | Address to Data Valid | | 8 | | 10 | | 12 | | 15 | ns |
| t_{OHA} | Data Hold from Address Change | 3 | | 3 | | 3 | | 3 | | ns |
| t_{ACE} | CE LOW to Data Valid | | 8 | | 10 | | 12 | | 15 | ns |
| t_{DOE} | OE LOW to Data Valid | | 5 | | 5 | | 6 | | 7 | ns |
| t_{LZOE} | OE LOW to Low-Z | 0 | | 0 | | 0 | | 0 | | ns |
| t_{HZOE} | OE HIGH to High-Z ^[7, 8] | | 4 | | 5 | | 6 | | 7 | ns |
| t_{LZCE} | CE LOW to Low-Z ^[8] | 3 | | 3 | | 3 | | 3 | | ns |
| t_{HZCE} | CE HIGH to High-Z ^[7, 8] | | 4 | | 5 | | 6 | | 7 | ns |
| $t_{PU}^{[9]}$ | CE LOW to Power-up | 0 | | 0 | | 0 | | 0 | | ns |
| $t_{PD}^{[9]}$ | CE HIGH to Power-down | | 8 | | 10 | | 12 | | 15 | ns |
| Write Cycle^[10, 11] | | | | | | | | | | |
| t_{WC} | Write Cycle Time | 8 | | 10 | | 12 | | 15 | | ns |
| t_{SCE} | CE LOW to Write End | 7 | | 8 | | 9 | | 10 | | ns |
| t_{AW} | Address Set-up to Write End | 7 | | 8 | | 9 | | 10 | | ns |
| t_{HA} | Address Hold from Write End | 0 | | 0 | | 0 | | 0 | | ns |
| t_{SA} | Address Set-up to Write Start | 0 | | 0 | | 0 | | 0 | | ns |
| t_{PWE} | WE Pulse Width | 6 | | 7 | | 8 | | 10 | | ns |
| t_{SD} | Data Set-up to Write End | 5 | | 5 | | 6 | | 8 | | ns |
| t_{HD} | Data Hold from Write End | 0 | | 0 | | 0 | | 0 | | ns |
| t_{LZWE} | WE HIGH to Low-Z ^[8] | 3 | | 3 | | 3 | | 3 | | ns |
| t_{HZWE} | WE LOW to High-Z ^[7, 8] | | 4 | | 5 | | 6 | | 7 | ns |

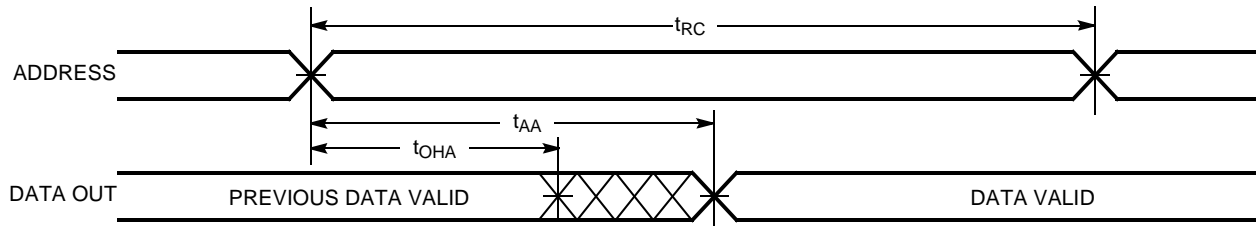
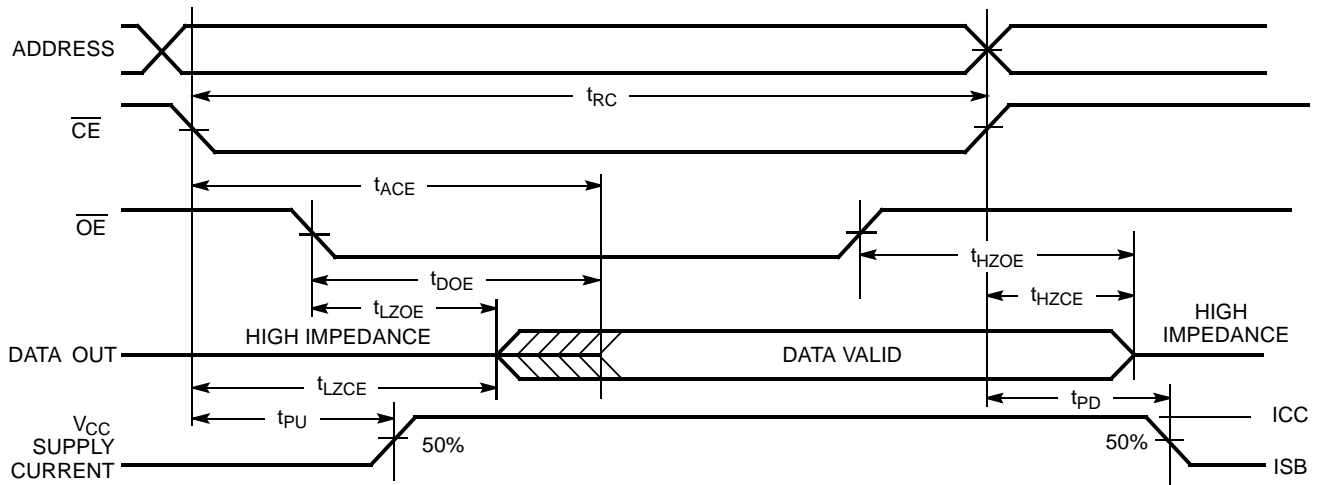
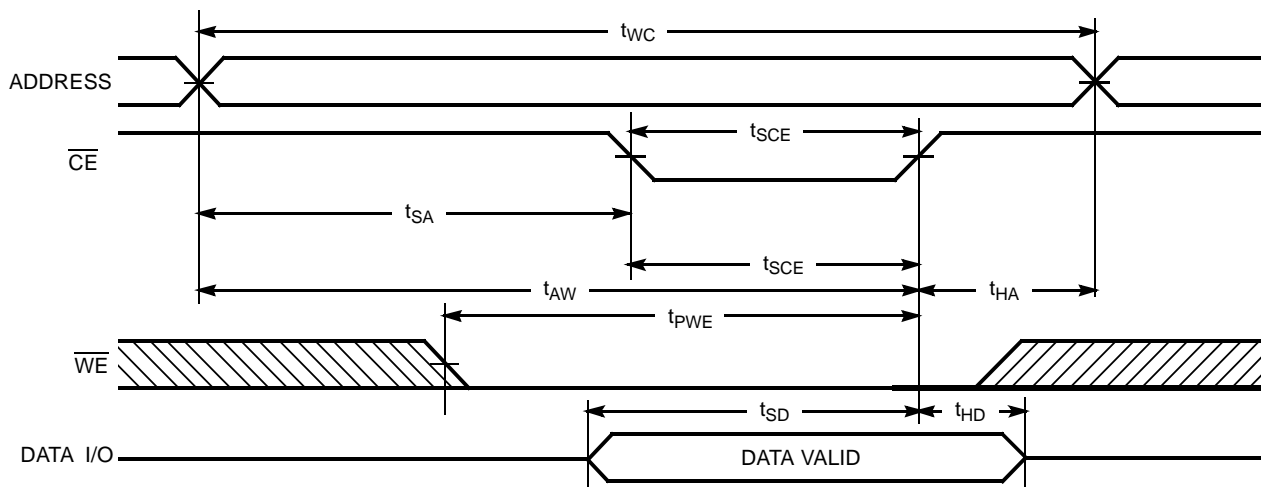
Notes:

- AC characteristics (except High-Z) for all 8-ns parts are tested using the load conditions shown in Figure (a). All other speeds are tested using the Thévenin load shown in Figure (b). High-Z characteristics are tested for all speeds using the test load shown in Figure (d).
- Test conditions assume signal transition time of 3 ns or less, timing reference levels of 1.5V, input pulse levels of 0 to 3.0V.
- t_{HZOE} , t_{HZCE} , and t_{HZWE} are specified with a load capacitance of 5 pF as in (d) of AC Test Loads. Transition is measured ± 500 mV from steady-state voltage.
- At any given temperature and voltage condition, t_{HZCE} is less than t_{LZCE} , t_{HZOE} is less than t_{LZOE} , and t_{HZWE} is less than t_{LZWE} for any given device.
- This parameter is guaranteed by design and is not tested.
- The internal Write time of the memory is defined by the overlap of \overline{CE} LOW and \overline{WE} LOW. \overline{CE} and \overline{WE} must be LOW to initiate a Write, and the transition of any of these signals can terminate the Write. The input data set-up and hold timing should be referenced to the leading edge of the signal that terminates the Write.
- The minimum Write cycle time for Write Cycle No. 3 (WE controlled, OE LOW) is the sum of t_{HZWE} and t_{SD} .

Switching Waveforms
Read Cycle No. 1^[12, 13]

Read Cycle No. 2 (\overline{OE} Controlled)^[13, 14]

Write Cycle No. 1 (\overline{CE} Controlled)^[15, 16]

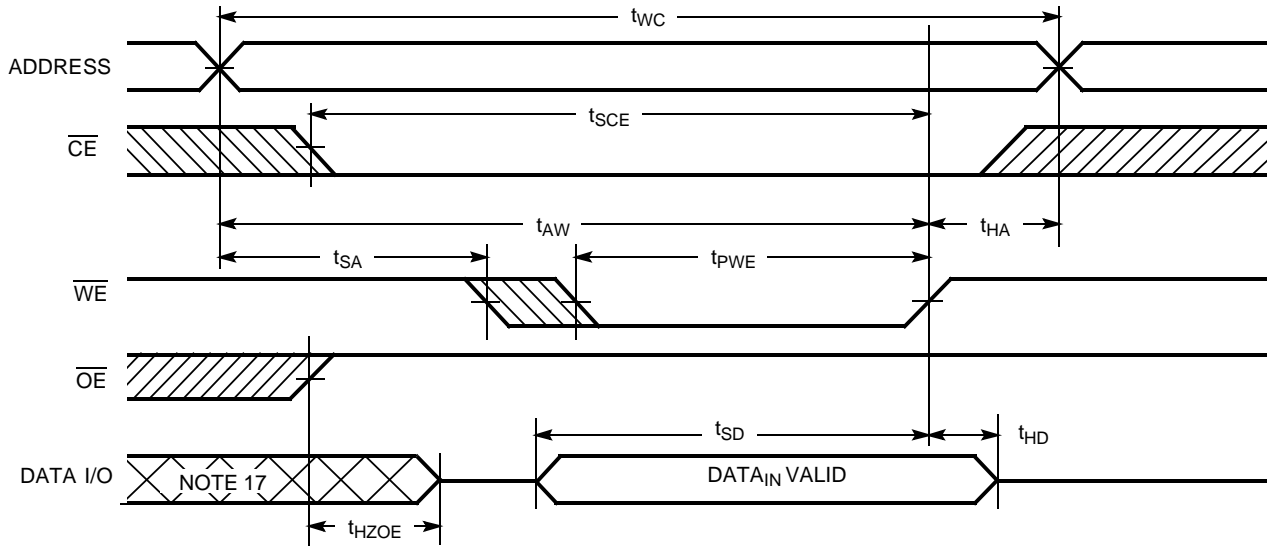
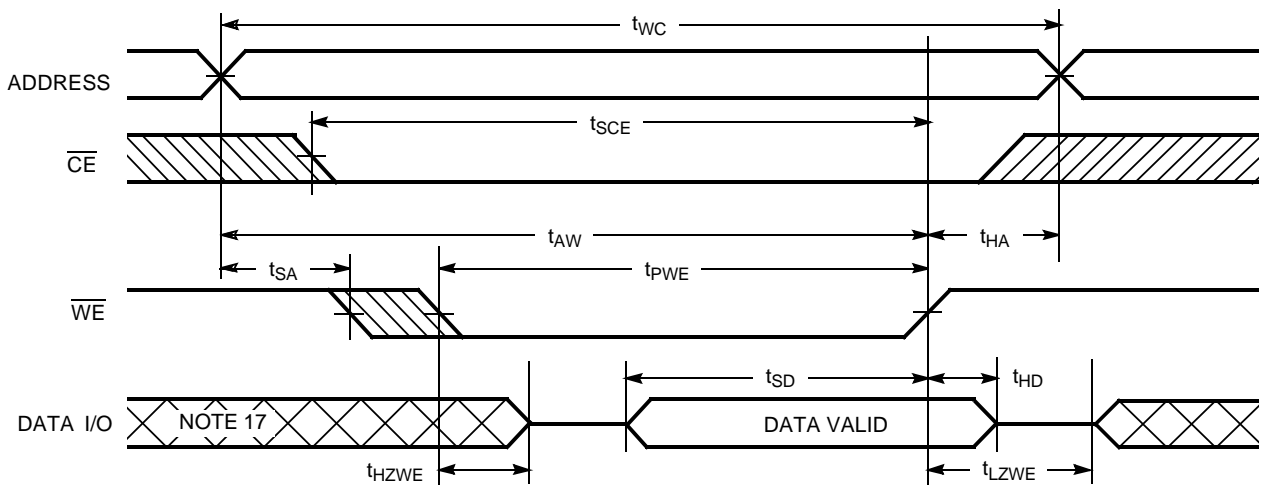
Notes:

12. Device is continuously selected. $\overline{OE}, \overline{CE} = V_{IL}$.
13. \overline{WE} is HIGH for Read cycle.
14. Address valid prior to or coincident with \overline{CE} transition LOW.
15. Data I/O is high impedance if $\overline{OE} = V_{IH}$.
16. If \overline{CE} goes HIGH simultaneously with \overline{WE} going HIGH, the output remains in a high-impedance state.

Switching Waveforms (continued)

Write Cycle No. 2 (\overline{WE} Controlled, \overline{OE} HIGH During Write)^[15, 16]

Write Cycle No. 3 (\overline{WE} Controlled, \overline{OE} LOW)^[11, 16]

Truth Table

| CE | OE | WE | I/O ₀ -I/O ₇ | Mode | Power |
|----|----|----|------------------------------------|----------------------------|----------------------|
| H | X | X | High-Z | Power-down | Standby (I_{SB}) |
| X | X | X | High-Z | Power-down | Standby (I_{SB}) |
| L | L | H | Data Out | Read | Active (I_{CC}) |
| L | X | L | Data In | Write | Active (I_{CC}) |
| L | H | H | High-Z | Selected, Outputs Disabled | Active (I_{CC}) |

Note:

17. During this period the I/Os are in the output state and input signals should not be applied.

Ordering Information

| Speed (ns) | Ordering Code | Package Name | Package Type | Operating Range |
|------------|-------------------|--------------|----------------------------|-----------------|
| 8 | CY7C1018CV33-8VC | V32 | 32-lead 300-mil Molded SOJ | Commercial |
| 10 | CY7C1018CV33-10VC | V32 | 32-lead 300-mil Molded SOJ | |
| 12 | CY7C1018CV33-12VC | V32 | 32-lead 300-mil Molded SOJ | |
| 15 | CY7C1018CV33-15VC | V32 | 32-lead 300-mil Molded SOJ | |

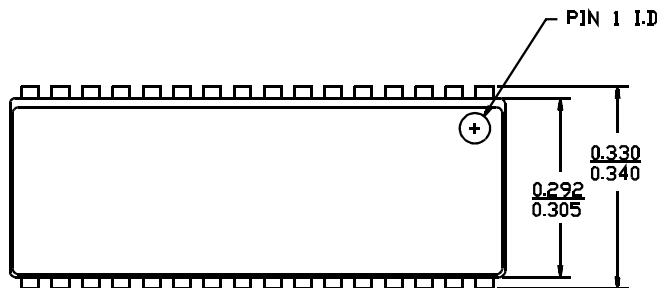
Package Diagram
32-lead (300-mil) Molded SOJ V32

 DIMENSIONS IN INCHES MIN.
MAX.

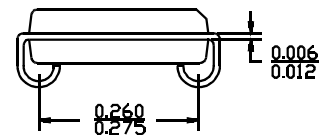
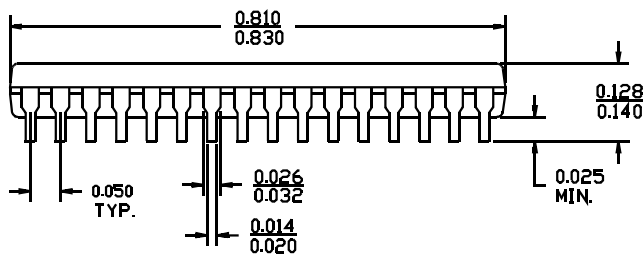
LEAD COPLANARITY 0.004 MAX.



51-85041-1A

All product and company names mentioned in this document are the trademarks of their respective holders.

Document History Page

| Document Title: CY7C1018CV33 128K x 8 Static RAM | | | | |
|---|----------------|-------------------|------------------------|---|
| Document Number: 38-05131 | | | | |
| REV. | ECN NO. | Issue Date | Orig. of Change | Description of Change |
| ** | 109426 | 12/14/01 | HGK | New Data Sheet |
| *A | 113432 | 04/10/02 | NSL | AC Test Loads split based on speed |
| *B | 115046 | 05/30/02 | HGK | I _{CC} and I _{SB1} modified |
| *C | 116476 | 09/16/02 | CEA | Add applications foot note on data sheet, pg 1. |